



Battery

Photovoltaic Systems 12V 100Ah (10Hours)

Model SIS-9430

Photovoltaic Systems 12V 100Ah (10Hours)

The rechargeable batteries are lead-lead dioxide systems. The dilute sulfuric acid electrolyte is absorbed by separators and plates and thus immobilized. Should the battery be accidentally overcharged producing hydrogen and oxygen, special oneway valves allow the gases to escape thus avoiding excessive pressure build-up. Otherwise, the battery is completely sealed and is, therefore, maintenance-free, leak proof and usable in any position.



Battery Construction

Component	Positive plate	Negative plate	Container	Cover	Safety valve	Terminal	Separator	Electrolyte
Raw material	Lead dioxide	Lead	ABS	ABS	Rubber	Copper	Fiberglass	Sulfuric acid

General Features

- Absorbent Glass Mat (AGM) technology for efficient gas recombination of up to 99% and freedom from electrolyte maintenance or water adding.
- Not restricted for air transport-complies with IATA/ICAO Special Provision A67.
- UL-recognized component.
- Can be mounted in any orientation.
- Computer designed lead, calcium tin alloy grid for high power density.
- Long service life, float or cyclic applications.
- Maintenance-free operation.
- Low self discharge.
- Case and cover available in both standard and flame retardant ABS.

Dimensions and Weight

- Length(mm / inch) 330 / 12.99
- Width(mm / inch) 171 / 6.73
- Height(mm / inch) 215 / 8.46
- Total Height(mm / inch) 222 / 8.74
- Approx. Weight(Kg / lbs) 29 / 63.9
- * Weight deviation: ±5%

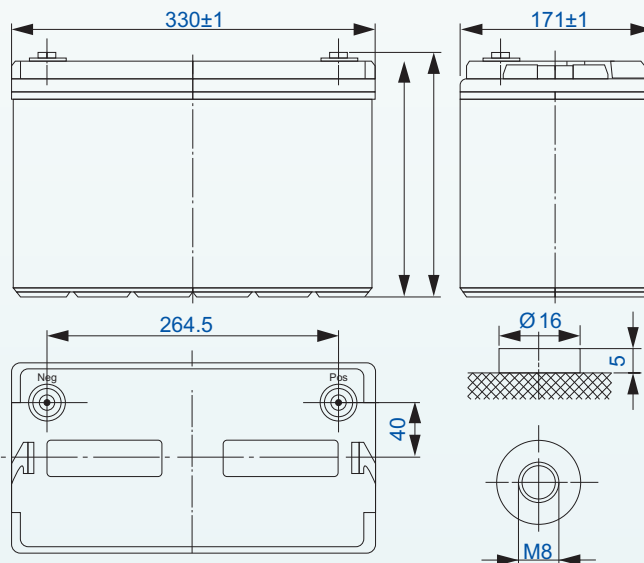

Performance Characteristics	
Nominal Voltage	12V
Number of cell	6
Design Life	10 years
Nominal Capacity 77oF(25oC)	
10 hour rate (10.0A, 10.8V)	100Ah
5 hour rate (16.6A, 10.5V)	83Ah
1 hour rate (61A, 9.6V)	61Ah
Internal Resistance	
Fully Charged battery 77oF(25°C)	≤5.7mOhms
Self-Discharge	
3% of capacity declined per month at 20°C(average)	
Operating Temperature Range	
Discharge	-20~60°C
Charge	-10~60°C
Storage	-20~60°C
Max. Discharge Current 77oF(25°C)	900A(5s)
Short Circuit Current	2100A
Charge Methods: Constant Voltage Charge 77oF(25°C)	
Cycle use	2.40-2.45VPC
Maximum charging current	30A
Temperature compensation	-30mV/°C
Standby use	2.20-2.28VPC
Temperature compensation	-20mV/°C

Discharge Constant Current (Amperes at 77°F25°C)

End Point Volts/Cell	10 min	15 min	30 min	1 hora	3 hora	5 hora	10 hora	20 hora
1.60 V	210	173	98.9	61.0	25.1	17.6	10.8	5.50
1.65 V	197	164	95.0	60.6	24.6	17.3	10.6	5.45
1.70 V	182	156	92.2	59.7	24.1	17.0	10.4	5.40
1.75 V	170	145	89.3	58.9	23.5	16.6	10.2	5.35
1.80 V	156	136	87.4	57.1	22.8	16.3	10.0	5.30

Discharge Constant Power (Watts at 77°F25°C)

End Point Volts/Cell	10 min	15 min	30 min	45 min	1 hora	2 hora	3 hora	5 hora
1.60 V	372	304	186	138	119	68.2	48.4	33.8
1.65 V	353	299	180	134	117	67.0	47.8	33.6
1.70 V	335	290	176	132	116	65.8	47.3	33.3
1.75 V	317	279	170	129	112	64.6	46.7	33.2
1.80 V	296	270	164	126	109	63.9	45.9	32.9

(Note) The above characteristics data are average values obtained within three charge/discharge cycles not the minimum values. All data shall be changed without notice, Vision reserves the right to explain and update the information contained hereinto.





Battery
Photovoltaic Systems 12V 100Ah (10Hours)
Model SIS-9430

